



Image shown may not reflect actual screen layout

EGP SWITCHGEAR CONTROLS

The standard and custom Cat® generator set paralleling switchgear is designed to integrate with EMCP generator set controls, providing a complete system with high efficiency and reliability.

Available in low and medium voltage system applications (up to 27 kV) the EMCP 3.S is an advanced, multifaceted microprocessor-based control found exclusively in Cat paralleling switchgear.

FEATURES

Emergency Generator Paralleling (EGP) Switchgear with EMCP 3.S for engine generator sets.

- Automatic Start, Synchronize, Parallel and Load Share on a common bus
- Main Lugs Output to feed downstream emergency distribution switchboard
- Optional Emergency Distribution circuit breakers
- Load shed/add control relays
- Generator demand priority
- For use with multiple downstream Automatic Transfer Switches (ATS)
- Cat generator set paralleling switchgear is designed to integrate with Cat Automatic Transfer Switches. EGP is optionally available with direct communication to Cat ATSs to provide complete control and monitoring from one convenient central location

EMCP 3.S brings the power and reliability of microprocessor technology to your generator power application. Through the use of the operator interface touchscreen display with easy to follow graphical presentations, the EMCP 3.S merges the features of:

- Power Monitoring
- Switchgear Automation
- Optional Remote Monitoring and Controls

TOUCHSCREEN INTERFACE

The color touchscreen display is the key to the system's powerful and simple operator interface. The screens give the operator an instantaneous, easily understandable view of the entire system status. To access system controls, simply touch the corresponding portion of the screen.

The easy-to-use touchscreen interface makes it possible to view and monitor:

- Engine and Generator Metering
- Protective relay settings
- Annunciators
- Adjust load shed controls and generator demand priority
- Synchronize and parallel
- Set modes of operations
- Voltage and frequency adjustments

CONTROLLER

Cat generator set paralleling switchgear has eliminated the single points of failure found in some controller schemes by integrating the following:

- 1) True distributed control processors for each power source ensures the system continues to operate even if a single processor fails.
- 2) Cat generator set paralleling switchgear uses moving master technology. Master control functions, such as modes of operation, load shed controls, generator demand priority controls and dead bus mitigation reside in the generator #1 EMCP 3.S. If generator #1 controller fails for any reason, the master control functions are automatically transferred to the next generator controller. Each generator controller is redundant to the first. As long as a generator set is available, Cat generator set paralleling switchgear will automatically bring it to the bus.
- 3) If the touchscreen fails, an "Instant Auto" switch is provided to place all software controls in the Auto position, protecting your facility from power outages.
- 4) Distributed manual control feature included.
- 5) Available redundant control networks.

STANDARD EQUIPMENT

- Choice of Operator Interface Touchscreen:
 - 19" Surface Acoustic Wave Color TFT
 - 12" Resistive Color TFT
 - 10" Resistive Monochrome
 - 6" Resistive Monochrome
- Direct data communication to Cat EMCP generator set control network
- System Overview screen with One Line Mimic Diagram which depicts real time metering, status and control
- Full Function 1% Accuracy Analog and Digital AC Metering for Generator and System monitoring: Voltage L-L, L-N; Current A, B, C phase; Frequency; Power Factor; kW; kVAR
- Full Function Engine Gauges: RPM, DC Battery Voltage, Oil Pressure, Engine Coolant Temperature, Engine Hours, Number of Starts
- Full Function Synchronizing and Paralleling Controls with Selection for Automatic or Manual Synchronizing
- NFPA 99/110 Engine/Generator Status, Pre-Alarm and Shutdown Fault Annunciation with color display and 85 dbA alarm horn with silence button
- System Control Functions for Auto (Standby for Emergency), test without load and test with load.
- Increased reliability with redundant hardwired back up to ensure generator power is available
- Automatic Load Shed Control with On-Screen Operator Adjustments for Essential (1 level of essential for every generator in the system) and 1

Level of Non-Essential Automatic or Manual Load Shed/Load Add Control

- Automatic Generator Demand Priority with On-Screen Operator Adjustments for Automatic Addition and Removal of Generator to the Load Bus
- System Status and Alarm Annunciation with color display and 85 dbA alarm horn with silence button
- Password secured Settings and Adjustments for Generator and System Setups and Protective Relaying
- Alarm Summary Reports
- Settings Reports
- Engine and Generator Load Charts
- Engine data with 3D engine graphic

OPTIONAL EQUIPMENT

- Redundant touchscreen
- Redundant communication networks
- Fiber optic communications for increased reliability
- Software for Additional On-Site Monitoring and Control Work Stations
- Software for Off-Site Monitoring and Control
- Building Automation Data Concentrator – Modbus or Ethernet
- Remote Notification
- Historical trend data for engine, generator, utility and system data.
- Extended Warranty

Standard Low Voltage Application Example

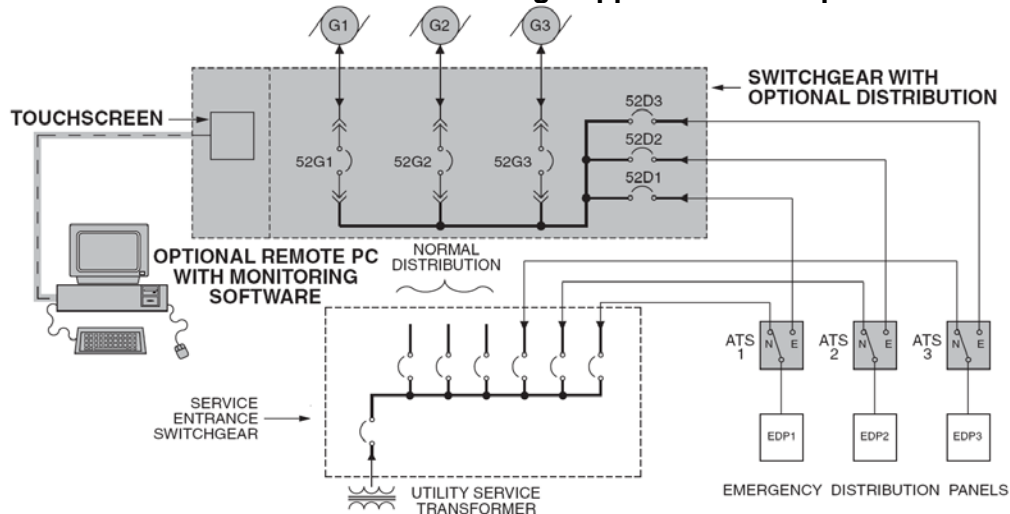

Information contained in this publication may be considered confidential. Discretion is recommended when distributing.

Materials and specifications are subject to change without notice.

CAT, CATERPILLAR, their respective logos, "Caterpillar Yellow", the "Power Edge" trade dress, as well as corporate and product identity used herein, are trademarks of Caterpillar and may not be used without permission.